

ANALYZER SOLUTIONS FOR YOUR PROCESS!

Model 5910 UHP Moisture Analyzer

PART-PER-TRILLION ANALYSIS FOR YOUR UHP GASES

AMETEK Process Instruments' Model 5910 UHP Moisture Analyzer achieves never-before-seen baseline stability and sensitivity to sub-ppbv changes in moisture concentration while providing one of the fastest response speeds available. The improvements in stability and sensitivity are the direct result of a design that is very carefully engineered to provide you with the best protection obtainable for your semiconductor gas system.

MORE RESPONSIVE CONFIRMATION OF GAS QUALITY WITHOUT FALSE ALARMS

How well is your facility protected from moisture contamination?

Why do you use moisture analyzers in your facility? You use them to protect your facility and its products from the costly results of contamination. To do this properly, it is necessary to know the actual ppbv moisture concentration in your facility piping—right now. Are you well-protected?

How do your current moisture analyzers calculate their output? How timely is that information? Most technologies take hours or days to respond to changes in ppbv moisture concentration due to their equilibrium-dependent readings. You'll see defective wafers long before those analyzers see the actual moisture concentration. To try to work around that physical limitation, those analyzers often use predictive modeling to improve their apparent speed of response. Predictive models often ignore the initial detection of a change in moisture, and then, after collecting enough data, make a prediction. Such predicting often results in false alarms or, worse yet, a false low reading. Simply put, an analyzer that has to guess at the actual moisture concentration is a tremendous compromise in quality that you cannot afford to make.

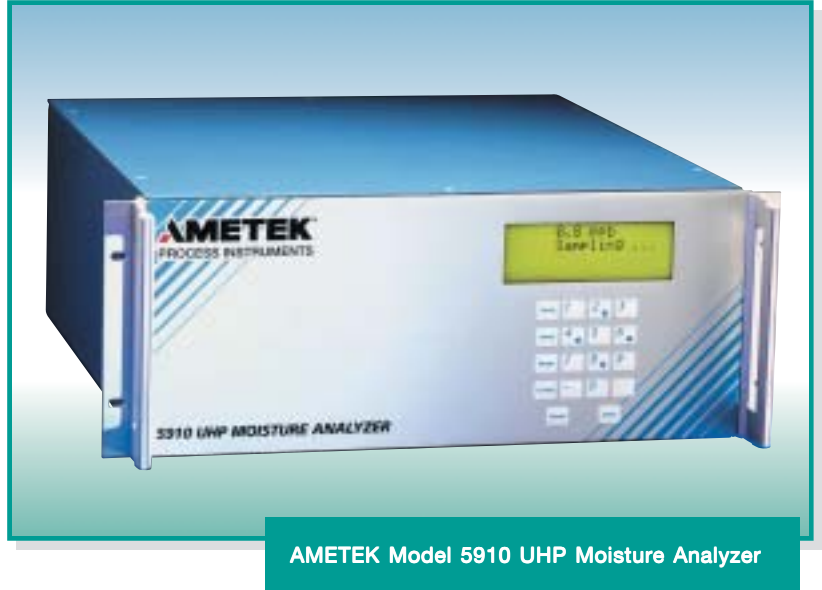

AMETEK Model 5910 UHP Moisture Analyzer

THE QUARTZ CRYSTAL SENSOR

The heart of the 5910 analyzer is a quartz-crystal microbalance (QCM) sensor and sampling system developed by AMETEK specifically for highly accurate moisture



measurements. The sensor consists of a pair of electrodes that support the QCM sensor. When voltage is applied to the sensor, a very stable oscillation occurs.

The faces of the oscillator are covered with a hygroscopic polymer. As the amount of moisture sorbed onto the polymer varies, the mass of the QCM changes, producing a corresponding change in the frequency of oscillation. This change is directly related to the moisture concentration of the surrounding gas.

At AMETEK, our Quartz Crystal Microbalance (QCM) moisture analyzers never guess because they don't have to! The nonequilibrium basis of our measurement guarantees this.

Sensitivity, Accuracy, Noise and Lower Detectable Limit

The Model 5910 provides a quantum leap forward in performance across all measurable parameters. The 5910 is sensitive to changes in moisture concentration of less than 500 pptv. We know this because the nominal noise level is below 50 pptv. The result of these phenomenal abilities is an accuracy of better than ± 100 pptv or $\pm 10\%$ of reading.

Speed of Response

At part-per-billion levels of moisture, a carefully designed and heat-traced analyzer is required to achieve a response speed measurable in minutes instead of hours. Rapid speed of response to changes of ppbv moisture can only be achieved through careful engineering attention to all sample-wetted parts. It is necessary to minimize surface roughness, surface area, sample volume, and to maintain an elevated surface temperature.

The 5910 is manufactured of welded, electropolished, UHP components that have the smoothest surfaces possible. These components are arranged so as to minimize the number that are upstream of the sensor. This design approach, when combined with the very small size of the QCM sensor, results in both the smallest surface area and the smallest sample volume of any available moisture analyzer technology. All of the wetted parts in the analyzer are housed within a temperature-controlled oven. The result is an unmatched speed of response to both increasing and decreasing moisture, typically reaching 80% of a 25 ppbv step change in either direction in less than 8 minutes. An even greater test of an analyzer's design is its response speed to even smaller changes in moisture concentration.

The performance graph demonstrates the response speed of the 5910 to a 3.4 ppbv challenge. This level of performance clearly demonstrates the careful design and consideration that goes into the 5910. When combined with the nonequilibrium operation of the quartz-crystal microbalance sensor, you receive a response speed unmatched by other moisture technologies such as aluminum-oxide, electrolytic, and laser-based analyzers as their response speeds are restricted by the physical limits of their surface areas and technology.

Easy-to-use, Multigas Compatibility

The Model 5910 is completely compatible with virtually all noncorrosive gases including the inerts (He, Ar, Ne, Xe, Kr), O₂, H₂, and N₂. Unlike some moisture analyzers that require special sensors for certain gases, the Model 5910 UHP uses a sensor that is not affected by the background gas. Even hydrogen and oxygen are simple gas streams to monitor since QCM sensors, unlike electrolytic sensors, do not suffer from recombination errors. Now, changing gases is a simple and quick selection from a software menu. There are no flow or pressure regulators for you to adjust.

Internal Verification

The 5910 has the ability to quickly and accurately verify its zero baseline. An internal dryer creates a zero gas from the sample gas, thereby allowing verification of the analyzer's baseline. This ensures that the analyzer's zero is actually zero—which is crucial because the goal of all UHP gases is to have the lowest moisture content possible. Other technologies do not have this benefit, leaving you to wonder if their zero is actually zero or some other higher or lower value.

TYPICAL APPLICATIONS

● Continuous Monitoring

Continuous moisture analysis is a valuable tool for quality assurance and process monitoring. As a quality assurance analyzer, the Model 5910 verifies that specified gas purity levels are maintained at on-site separation, bulk delivery and distribution system transfer points, and ultimately, at points-of-use. The Model 5910 satisfies all the demands of continuous monitoring—principally low detection limit, high measurement accuracy, and internal verification.

● Analytical Carts

The Model 5910 is the perfect analyzer for temporary monitoring applications for verifying installation, maintenance, or repair of gas distribution systems. Such temporary or spot testing makes excellent use of the unique combination of capabilities provided by the Model 5910—very fast response speed, especially to decreasing moisture concentrations for monitoring system dry-down; complete compatibility with O₂, H₂, and inerts; rapid start-up response; and the ability to quickly change from one gas to another.

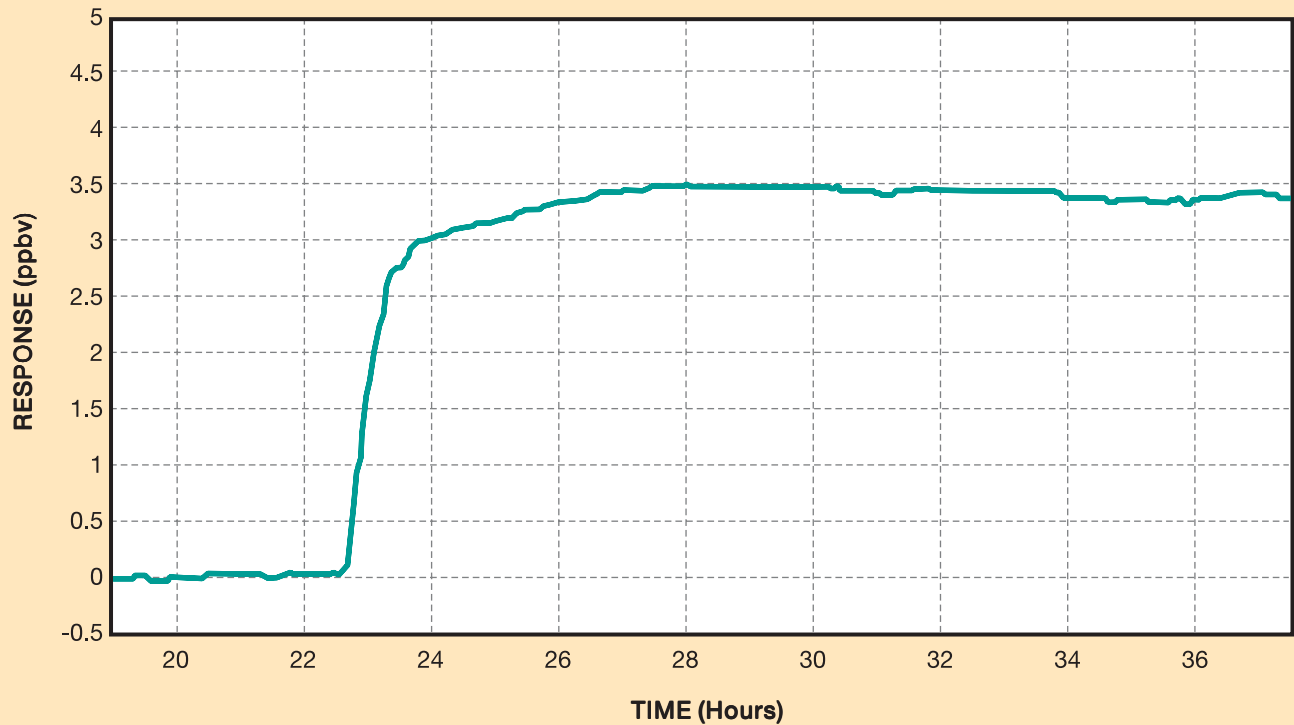

NONEQUILIBRIUM OPERATING THEORY OF QCM

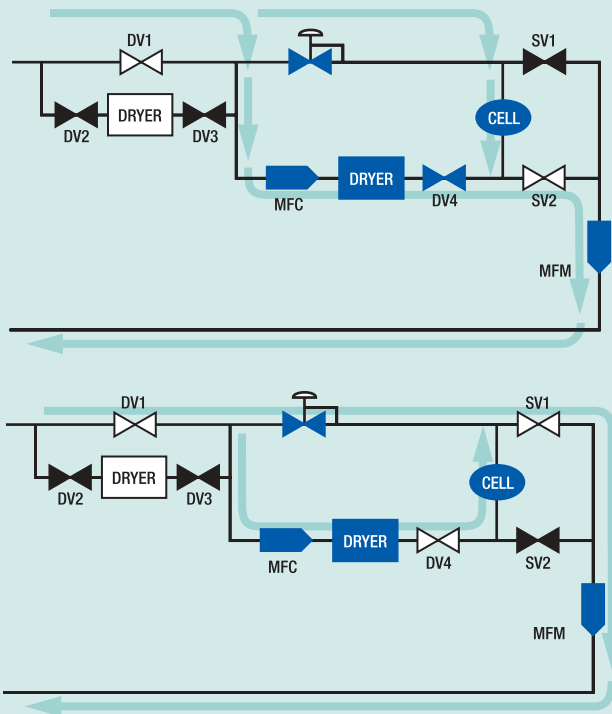

The analyzer systematically cycles between the actual process gas and a dried reference gas. During the process gas cycle (top), moisture molecules accumulate on the surface of the QCM sensor. During the reference gas cycle (bottom), these water molecules are swept off the surface of the sensor by the dry gas flow. Since there is no waiting for equilibrium, the system provides a measurement of moisture concentration every cycle.

The number of water molecules that accumulate on the surface of the sensor is a function of the difference in moisture between the process gas and reference gas. The analyzer compares the process gas with the known, dry reference—as opposed to trying to measure an absolute value that only occurs once equilibrium has been achieved. When a high moisture event occurs, the Model 5910 responds quickly to alert you to the problem. After the high moisture event passes, the nonequilibrium nature of the Model 5910 means that no long dry down period is ever needed before you will get accurate low ppbv measurements.

PERFORMANCE SPECIFICATIONS

Compatible Gases: Inerts (He, Ar, Ne, Xe, Kr), O₂, H₂, N₂.
O₂ requires a special purifier. (Contact the factory to confirm compatibility with other gases.)

Range: Calibrated from 0 to 150 ppbv. Operating range to 1000 ppbv.

Limit of Detection: 150 pptv nominal

Accuracy: ±100 pptv or ±10% of the reading, whichever is greater

RMS Noise: 50 pptv

Response Time: Typically 80% of a 25 ppbv step change in either direction in 10 minutes or less

Inlet Pressure: 20 to 50 psig (138 to 345 kPa). Specified performance is obtained when the inlet gas pressure is maintained within ±2.5 psi (±17 kPa).

Exhaust Pressure: Atmospheric

Sample Flow Requirement: less than 3 slpm

Inlet Gas Temperature: 32° to 212°F (0° to 100°C). Optimal results are obtained when the inlet gas temperature is maintained at 140°F (60°C).

Outputs

Four-line by twenty-character LCD display
One self-powered 4 to 20 mA, into 100 to 500 ohm load analog output; can be configured for loop-powered operation
RS485 and RS232 serial ports

Alarms: System alarm, concentration alarm, and data valid
30 VAC or 60 VDC max, 50 VA or 1A max, resistive

Environmental Conditions

Ambient temperature range 50° to 86°F (10° to 30°C).
Optimal results are obtained when ambient is maintained within ±9°F (±5°C).
Relative humidity 90%, noncondensing
Pollution Degree 2
Maximum altitude 6560 feet (2000 meters)
Installation Category II
Indoor use only

Utility Requirements

100-132 VAC or 230 VAC ±10%, 47-63 Hz, 185W
Instrument Air: 80 to 100 psi (550 to 690 kPa),
-40°C dew point

Mounting Configuration: 19-inch rack

Dimensions (W x H x D): 19 x 7 x 20 in. (48 x 17.7 x 50.9 cm)

Net Weight: 35 lb. (15.9 kg)

Approvals and Certifications

UL/CSA General Safety Requirements
UL/CSA Class I, Division 2, Groups A, B, C, D T4
Complies with all Relevant European Directives

One of a family of innovative process analyzer solutions from AMETEK Process Instruments. Specifications subject to change without notice.



CANADA
2876 Sunridge Way N.E.
Calgary, AB T1Y 7H9
Ph. 403-235-8400
Fax 403-248-3550

USA - Delaware
455 Corporate Blvd.
Newark, DE 19702
Ph. 302-456-4400
Fax 302-456-4444

USA - Pittsburgh
150 Freeport Road
Pittsburgh, PA 15238
Ph. 412-828-9040
Fax 412-826-0399

USA - Texas
9750 Whithorn Drive
Houston, TX 77095
Ph. 281-463-2820
Fax 281-463-2701

CHINA
Ph. 86 21 6426 7049
Fax 86 21 6426 7054

FRANCE
Ph. 33 1 30 68 69 20
Fax 33 1 30 68 69 29

GERMANY
Ph. 49 21 59 91 36 0
Fax 49 21 59 91 36 80

MIDDLE EAST - Dubai
Ph. 971-4-881 2052
Fax 971-4-881 2053



www.ametekpi.com
© 2002, by AMETEK, Inc. All rights reserved.
5910 UHP (10/18/02)

