

The Computerized Calibration System CGM –

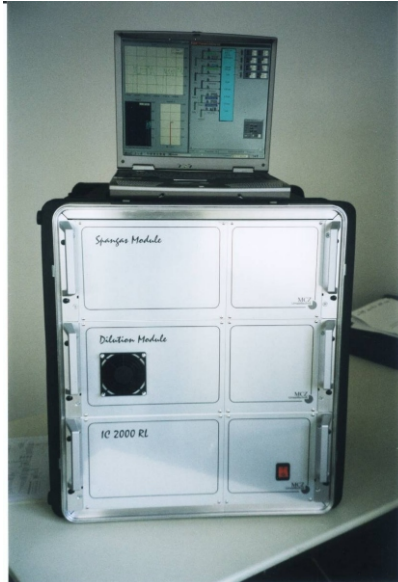

CGM with option external data acquisition and second dilution step
Laptop for control software

Calibration System CGM

The calibration system CGM enables the automation of such routine tasks as calculation and adjustment of span gas concentrations. It is possible to set up complete test programs for multi-point calibrations.

Up to eight span gas modules can be controlled with the software. Software runs on PC under Windows 98, Windows NT or 2000. The mass flow controller, and the ozone source can be calibrated by software with a twenty point calibration.

The system is designed for the calibration of gas analyzers and gas chromatographs and to assure quality in the lab and during the production of devices.

Available options

- Ozone Generator
- Multi-Component, Multi-Point Gas Mixer
- Gas Phase Titration
- Permeation Oven
- external Data Logger
- Multi-Event Programming
- Calibrate Mode for MFC and Ozone Generator

The CGM calibration system is a modular system and can be enhanced or modified at any time. All system functions are controlled via an external computer. The desired span gas concentrations are entered into the Windows software, the setting and regulation of the gas flows takes place automatically by the integrated electronics..

During multi-point calibrations, the span gas concentrations are changed automatically at a preprogrammed time. An optional available external data logger can register and store the measuring data of the to be calibrated analyzers. Subsequently, the measuring data can be evaluated with optional utility programs.

Umwelttechnik MCZ GmbH
Dieselstrasse 20a
61239 Ober-Moerlen
Tel. +49(0)6002 1711
Fax. +49(0)6002 1713

Calibration System CGM

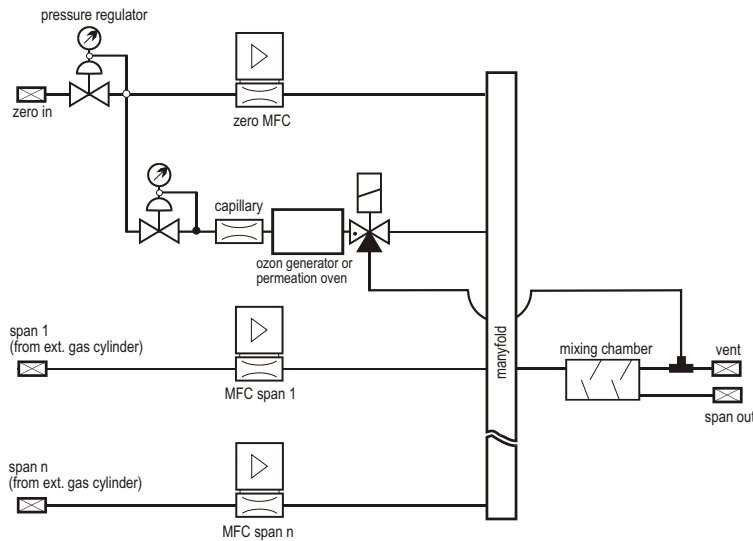

The calibrating system CGM consists of different modules. The basic unit contains the entire control electronics, the mass flow controller for the dilution, the inlet pressure controller for zero gas, and the mixing chamber. Optionally, the system can be equipped with ozone generators, permeation modules and MFC with external span gas inlets. The electronics is able to control up to 8 span gas modules.

The operating Windows software is already set up for all additional modules and can be configured via parameters on an external PC.

Specifications

BASIC SYSTEM

Accuracy of flow	$\pm 1\%$ full scale (analog MFC) $\pm 0,75$ from actual value plus $\pm 0,25\%$ FS (digital MFC)
Repeatability	$\pm 0,25\%$
Operating temperatures	5 bis 40° C
Power consumption	typ. 15 W / 150 W max.
Mechanical	19" / 4 HE; 5 to 18 kg

OZONE GENERATOR

Principle optical	UV-source linearized and temperature stabilized, equipped with a photo-feedback circuit; Ozon output 5 to 600 ppb at up to 2,5 l/min (other on request, max 25ppm)
----------------------	--

PERMEATION OVEN

Principle	Temperature regulation withs Peltier elements, wetted surfaces Borosilikat glas; Temperature range oven 20 to 70° C or 20 to 110° C
Accuracy	$\pm 0,05^\circ$ C
Miscellaneous	seriell port for connection with PC, external data acquissition modul